

FIELD SERVICE BULLETIN

Navion



RYAN AERONAUTICAL COMPANY, LINDBERGH FIELD, SAN DIEGO 12, CALIFORNIA

FIELD SERVICE BULLETIN NO. 23
5 DECEMBER 1955

MANDATORY

TO: ALL NAVION DISTRIBUTORS, DEALERS AND OWNERS

SUBJECT: INSPECTION AND/OR REPAIR OF REAR WING SPAR JUNCTION FITTINGS

EFFECTIVITY: ALL NAVIONS

ACCOMPLISH: IMMEDIATE INSPECTION AND REPAIR ON OR BEFORE 1 FEBRUARY 1956

1. Inspection of some Navion aircraft has revealed that cracks may exist in the right, left, or both rear wing spar junction fittings at wing sta. 0.00. Immediate inspection of fittings 145-14070 must be made by removing the bolt connecting the right and left fittings. Access to fittings is through main wheel wells, facing aft.
2. Install back plate, shown on attached sketch, in each fitting.
3. If cracks do exist, stop-drill end of cracks with #60 (.040) drill and install back plates in each fitting.
4. No further inspection will be necessary.
5. It is understood that a C. A. A. airworthiness directive covering this subject will be issued at an early date.

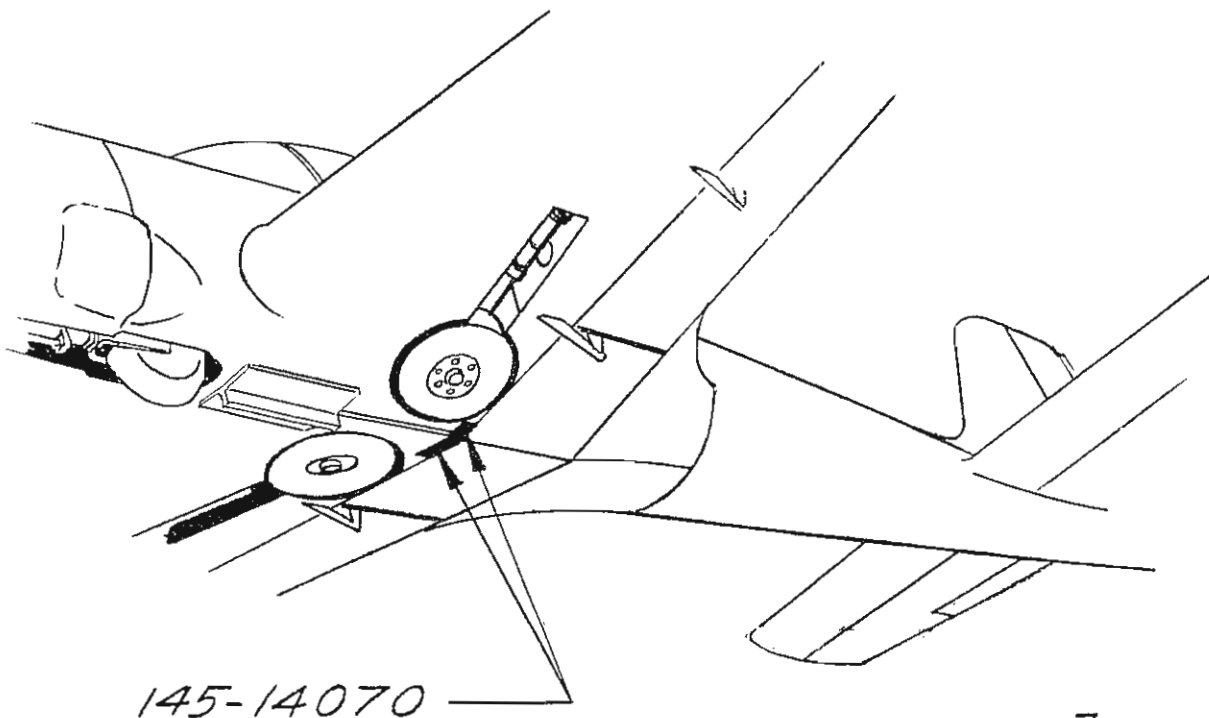

145-14070

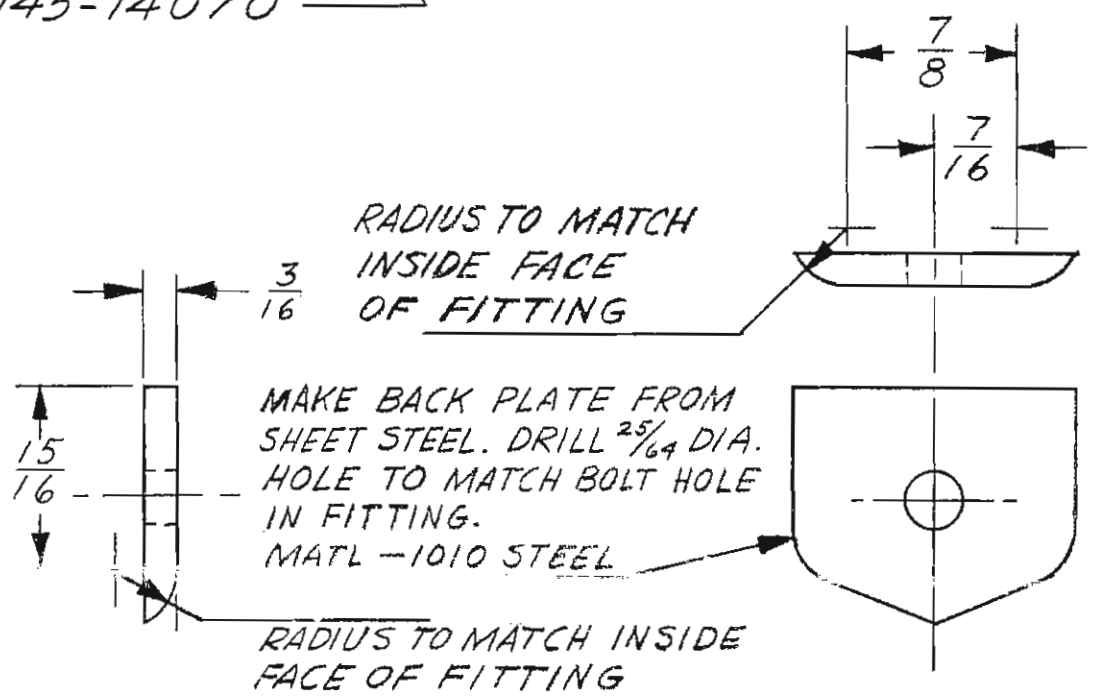

BACK PLATE



145-14070 FITTING -
WING REAR SPAR TO
CENTER RIB ATTACH

DRILL #60 (.040) DIA.
HOLE AT END OF
CRACK TO PREVENT
FURTHER CRACKING

